

Flexible connector set

for connecting distributors and manifolds
for oil and fluid grease

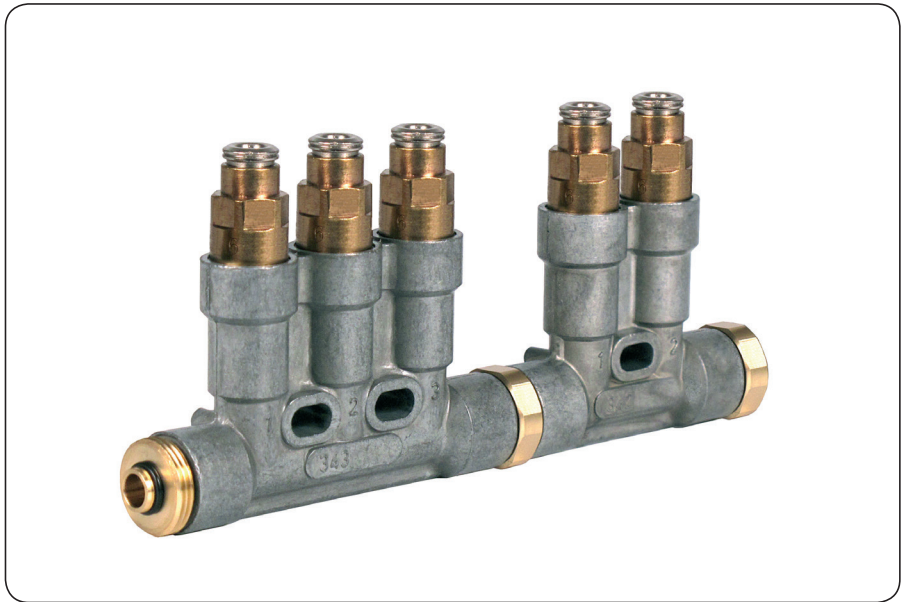

- Connect distributors and manifolds of the same and different sizes
- Simple and fast installation
- Continuously variable positioning
- No limit on number of disconnects
- Leak-tight

Flexible connector set

Fields of application and functional description

With flexible connector set, SKF single-line distributors and SKF manifolds of the same and different sizes can be interconnected securely, quickly, and leak-free. Soft packing allows for continuously variable orientation of the distributors or manifolds to one another. This also eliminates the need for additional flat packing which has conventionally been used for installing distributors and manifolds. There is no limit on the number of times these leak-tight connections can be detached, allowing for easy and repeated assembly and disassembly.

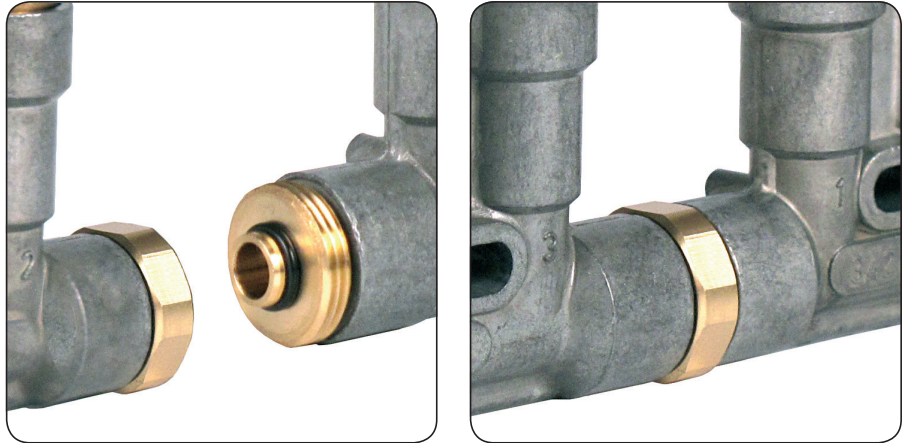

The flexible connector set consist of multiple components: the threaded nipple with O-ring and sealing ring as well as the screw bush with union nut and sealing ring. To connect two distributors or manifolds, the threaded nipple is screwed into one component and the screw bush with union nut is screwed into the other component.

The first of the two components can now be mounted. Both components are then connected using the union nut. The second component can now be mounted securely. Changing the position of the interconnected components involves merely loosening the union nut.

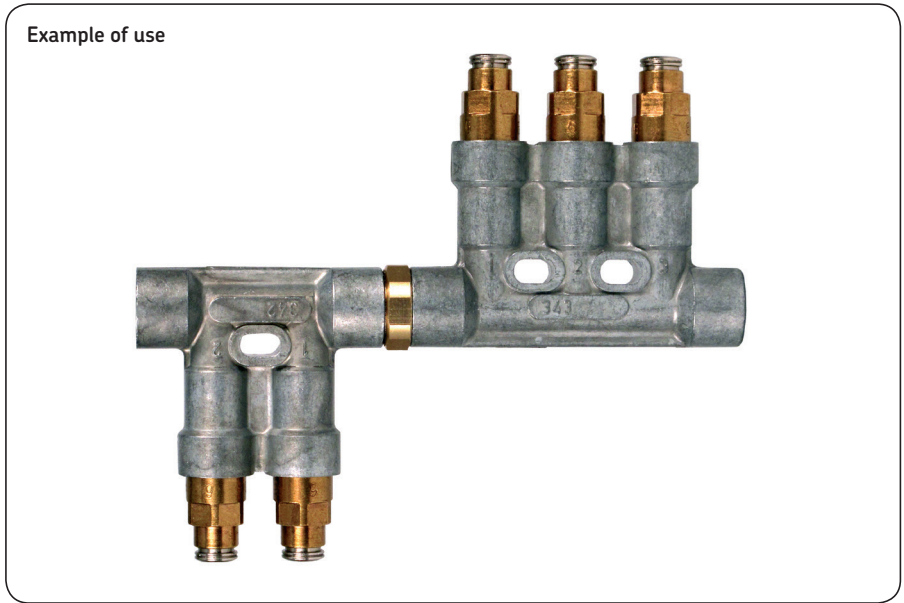
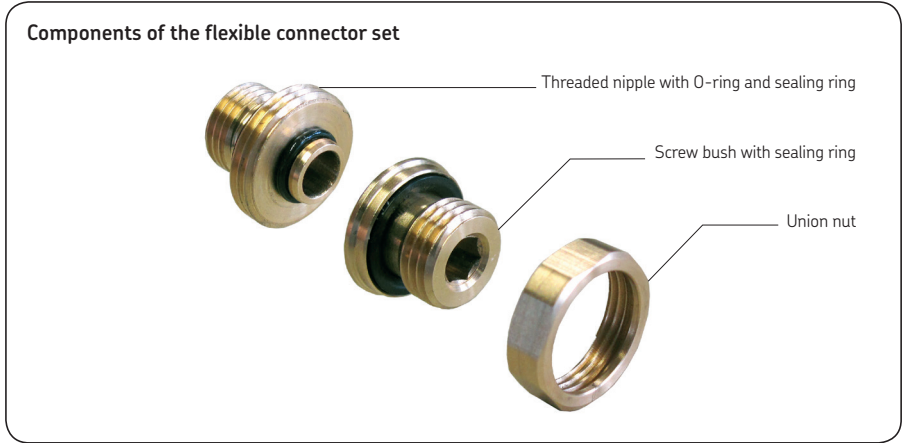

Flexible connector set

Dimensions and technical data

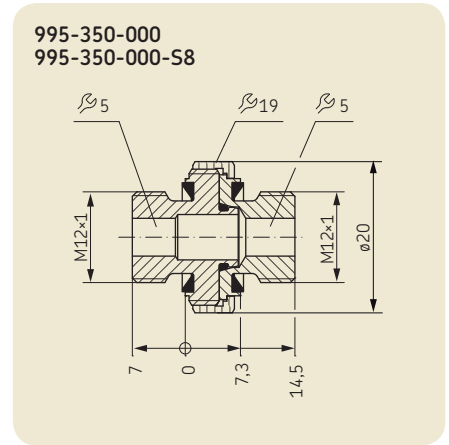
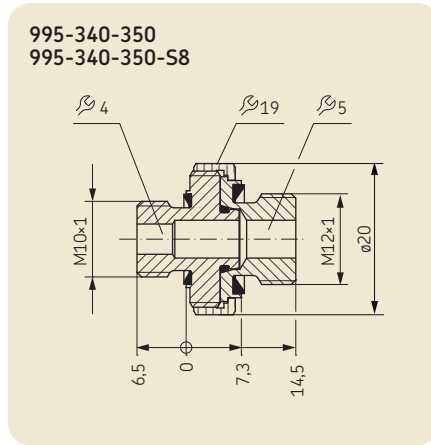
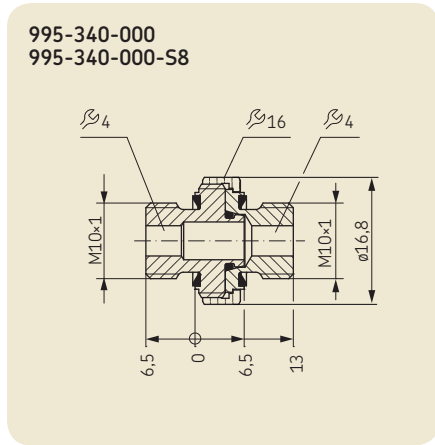

Technical data

Order No.	Thread left-hand	Thread right-hand	Material ¹⁾	Weight [g]	Recommended tightening torques [Nm]
995-340-000	M10x1	M10x1	Brass/NBR	14	$\varnothing 4 = 3,5^{+0,5}$ $\varnothing 5 = 5,0^{+0,5}$ $\varnothing 16 = 3,5^{+0,2}$ $\varnothing 19 = 5,0^{+0,2}$
995-340-000-S8	M10x1	M10x1	Brass/FKM (FPM)	14	
995-340-350	M10x1	M12x1	Brass/NBR	18	
995-340-350-S8	M10x1	M12x1	Brass/FKM (FPM)	18	
995-350-000	M12x1	M12x1	Brass/NBR	22	
995-350-000-S8	M12x1	M12x1	Brass/FKM (FPM)	22	

¹⁾ Grease the seals with a suitable lubricant during mounting!

Spare parts

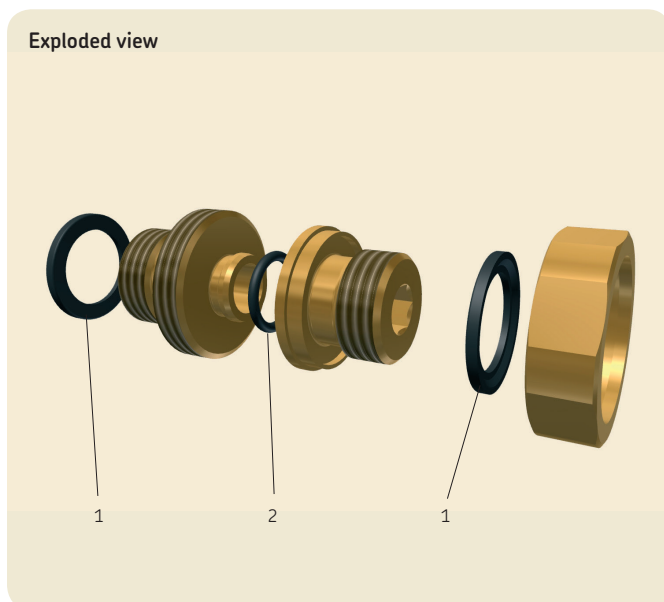

Spare parts list

Item	Description	Order No.
1	NBR sealing ring for M10x1	943-410-121
1	FKM (FPM) sealing ring for M10x1	943-410-121-S8
1	NBR sealing ring for M12x1	943-412-151
1	FKM (FPM) sealing ring for M12x1	943-412-151-S8
2	NBR O-ring for 995-340-000	WVN501-6x1
2	FPM (FKM) O-ring for 995-340-000	WVN532-6x1
2	NBR O-ring for 995-340-350, 995-350-000	WVN501-7x1
2	FPM (FKM) O-ring for 995-340-350, 995-350-000	WVN532-7x1

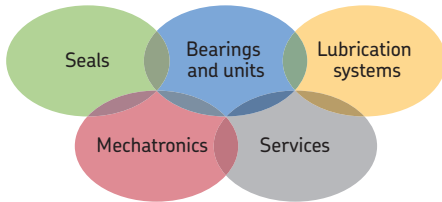

The Power of Knowledge Engineering

Drawing on five areas of competence and application-specific expertise amassed over more than 100 years, SKF brings innovative solutions to OEMs and production facilities in every major industry world-wide. These five competence areas include bearings and units, seals, lubrication systems, mechatronics (combining mechanics and electronics into intelligent systems), and a wide range of services, from 3-D computer modelling to advanced condition monitoring and reliability and asset management systems. A global presence provides SKF customers uniform quality standards and worldwide product availability.

! Important information on product usage

All products from SKF may be used only for their intended purpose as described in this brochure and the operating instructions. If operating instructions are supplied together with the products, they must be read and followed.

Not all lubricants can be fed using centralized lubrication systems. SKF can, on request, inspect the feedability of the lubricant selected by the user in centralized lubrication systems. Lubrication systems and their components manufactured by SKF are not approved for use in conjunction with gases, liquefied gases, pressurized gases in solution, vapors or such fluids whose vapor pressure exceeds normal atmospheric pressure (1 013 mbar) by more than 0,5 bar at their maximum permissible temperature.

In particular, we call your attention to the fact that hazardous materials of any kind, especially the materials classified as hazardous by EC Directive 67/548/EEC, Article 2, Para. 2, may only be filled into SKF centralized lubrication systems and components and delivered and/or distributed with the same after consultation with and written approval from SKF.

Further brochures

- | | |
|------------------|---|
| <i>1-0103-EN</i> | <i>Fittings and Accessories</i> |
| <i>1-5001-EN</i> | <i>Lubricant Distributors</i> |
| <i>1-9201-EN</i> | <i>Transport of Lubricants in Centralized Lubrication Systems</i> |

SKF Lubrication Systems Germany GmbH

Berlin Plant
 Motzener Str. 35/37 · 12277 Berlin
 PO Box 970444 12704 Berlin Germany

Tel. +49 (0)30 72002-0
 Fax +49 (0) 30 72002-111

This brochure was presented to you by:

© SKF is a registered trademark of the SKF Group.

© SKF Group 2014

The contents of this publication are the copyright of the publisher and may not be reproduced (even extracts) unless prior written permission is granted. Every care has been taken to ensure the accuracy of the information contained in this publication. However, no liability can be accepted for any loss or damage, whether direct, indirect or consequential, arising out of use of the information contained herein.

PUB LS/P2 13865 EN · July 2014 · 1-0103-2-EN

